



## Mastering Innovations

We offer modern tools and equipment for the electrical and control systems engineering over 20 years.

Customer-oriented service and intelligent system solutions are part of a successful and profitable partnership for us.

## Content

Busbar fabrication	
Cutting	
HSBL-2 Cutting Tool	1
Punching	
HSBL-2 Punching Tool	2
HSBL-2 DigiPunch 160	3
Bending	
HSBL-2 Bending Tool	5
Digital Bending Bench BGD-5eco	6
Digital Bending Bench BGD-5.1	10
Busbar Center	
3 in 1 Busbar Center SLB 125	14
Complete Systems	
HSBL-2 Starter System	20
HSBL-2 Basic System	21
HSBL-2 Standard System	22
HSBL-2 Profi System I	23
HSBL-2 Profi System II	26
Hydraulic Power Packs	
Hydraulic Power Packs HA1-ES and HA3	29

HSBL-2 System

**HSBL-2 System**  
Cutting Tool

HSBL-2 System  
Punching Tool

HSBL-2 System  
Bending Tool

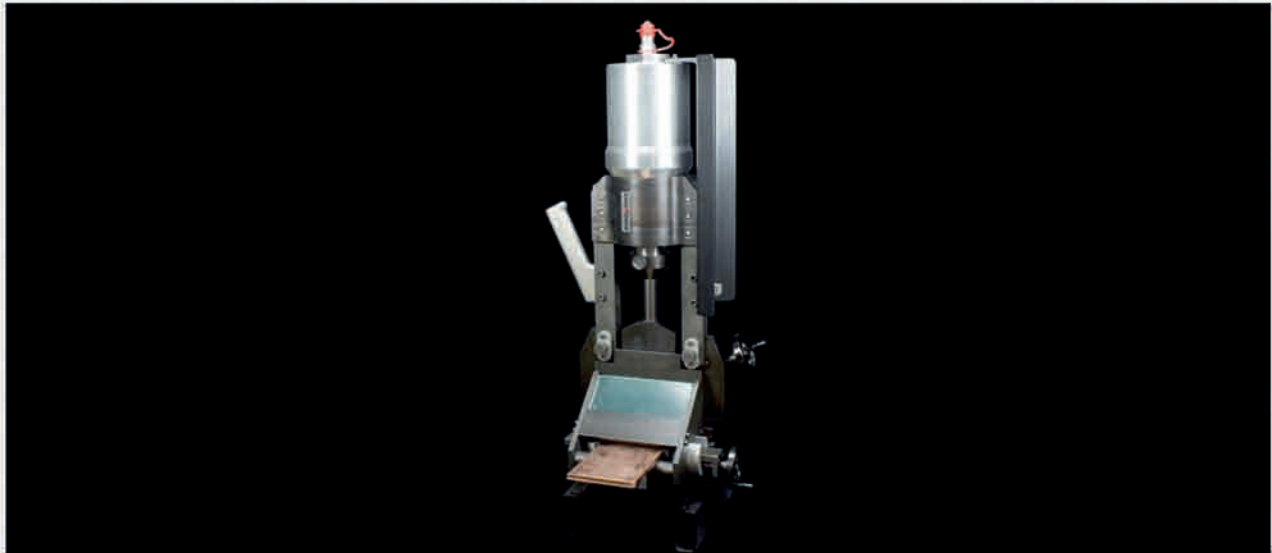

**HSBL-2 Cutting Tool**  
Ref.No. 7020

For portable and stationary cutting applications up to 160 x 13 mm (6"x1/2") the HSBL-2 Cutting Tool 160 is the ideal choice for professional busbar production. State of the art operator safety and additional accessories like Stop Device are making the HSBL-2 Cutting Tool 160 an integrated part of our busbar production lines.

**Technical specifications**  
Ref.No. 7020

Height	940 mm (incl. work-cylinder)
Depth	310 mm
Width	400 mm
Weight	53.9 kg (incl. work-cylinder)
Operating pressure	150 bar (2,200 psi)
Force	150 kN
Cutting max.	160 x 13 mm 250 N/mm <sup>2</sup>
Cycle time	15 sec.

Recommended Power Pack is HA3.



**HSBL-2 Cutting Tool**  
Advantages

- ▶ Excellent cutting quality by symmetric knives
- ▶ Long-lasting cutting knives
- ▶ Short cycle times about 15 sec.
- ▶ High safety standards

Work Cylinder HSBL-2	Ref.No. 2420
Cutting Tool 160	Ref.No. 7020
Vice for 7020	Ref.No. 7030
Stop Device for 7020	Ref.No. 8990



Ref.No. 6990

Ref.No. 7030

We reserve the right to make technical modifications.



HSBL-2 System

HSBL-2 System  
Cutting Tool

**HSBL-2 System**  
Punching Tool

HSBL-2 System  
Bending Tool



### HSBL-2 Punching Tool

Ref.No. 7050

For portable and stationary punching applications up to 160 x 13 mm (6"x1/2") the HSBL-2 Punching Tool 160 is the ideal choice for our busbar production. State of the art operator safety and the additional X-Y positioning device will vanquish the need for premeasuring and center marking on your busbar. Excellent punching quality with round, elongated and square dies are making the HSBL-2 Punching Tool 160 the ideal option for small and medium work shops.

### Technical specifications

Ref.No. 7050

Height	900 mm (incl. work-cylinder)
Depth	310 mm
Width	460 mm
Weight	56.8 kg (incl. work-cylinder)
Operating pressure	150 bar (2.200 psi)
Force	150 KN
Punching perf. max.	160 x 13 mm 250 N/mm <sup>2</sup>
Cycle time	5.5 sec.*

Recommended Power Pack is HA3.  
\* Busbar 120x10 mm



### HSBL-2 Punching Tool Advantages

- ▶ Excellent punching quality burr free
- ▶ Easy positioning in X/Y- axis
- ▶ Large assortment of round, elongated and square dies
- ▶ Fast and easy tool change

Work Cylinder HSBL-2	Ref.No. 2420
Punching Tool 160	Ref.No. 7050
Stop Device for 7050	Ref.No. 7190
Punching Tool 160 incl. Stop Device	Ref.No. 34243

We reserve the right to make technical modifications.



## HSBL-2 DigiPunch 160



### HSBL-2 DigiPunch 160 Ref.No. 40800 & 40900

With the DigiPunch 160, Novopress offers a new class of busbar punching performance for medium-sized enterprises. Wherever manual punches are insufficient and CNC-controlled machines are too costly, the DigiPunch 160 is the ideal mid-size solution. It reduces manufacturing time and cost significantly, at a very modest investment compared to CNC-punches. The very practical configuration with digital metering in X/Y axis and complete conveyors, enables a very efficient busbar manufacturing.

### Technical specifications

Height	1,900 mm
Depth	550 mm
Width	4,300 mm
Weight	160 kg
Operating pressure	150 bar (2,200 psi)
Force	150 KN
Busbar size max.	3,000 x 160 x 13 mm
Max. measuring range	2,000 x 180 mm
Metering resolution	0.5 mm

Recommended Power Pack is HA3.



### Advantages

- ▶ Significantly reduced manufacturing cost on medium to medium-large output volume
- ▶ Optimized and speedy work flow through integrated conveyor system and work-bench
- ▶ No programming or preparatory work required, very short set-up times
- ▶ Fast and stepless positioning of busbars in X and Y axis, with 0.5 mm accuracy
- ▶ Switching from absolute- to chain-measurement for fast and easy progressive punching

DigiPunch160	Ref.No. 40800
Incl. HSBL-2 Work Cylinder and Power Pack HA3	Ref.No. 40900

We reserve the right to make technical modifications.

## HSBL-2 DigiPunch 160



### New progressive punching dies

Also the punching dies are new designed and further reduce manufacturing cost. Punch and die are interchangeable by quick lock mechanism within 20 sec. The solid die-holder enables progressive punching for oblong and slotted wholes. Switching from absolute to chain measurement, offers fast progressive punching without extra calculating. Last but not least we offer a large assortment of punching dies, especially matched with the needs of the electrical industry.

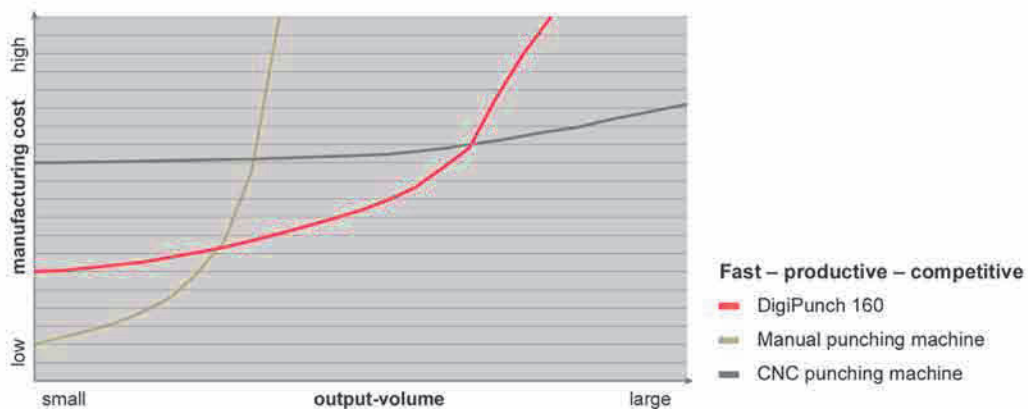

We reserve the right to make technical modifications.

HSBL-2 System

HSBL-2 System  
Cutting Tool

HSBL-2 System  
Punching Tool

**HSBL-2 System**  
Bending Tool



### HSBL-2 Bending Tool

Ref.No. 1179

The Hydraulic Bending Tool 120 is ideal for portable use and smaller works up to 120 x 10 mm. A Hydraulic Stop for adjusting the bending angle is available as an accessory.

Work Cylinder HSBL-2	Ref.No. 2420
Bending Tool 120	Ref.No. 1179
Hydraulic Stop for 1179	Ref.No. 1627

We reserve the right to make technical modifications.



**BGD-5eco**  
Digital Bending Bench

BGD-5eco  
Technical specifications

BGD-5eco  
Accessories

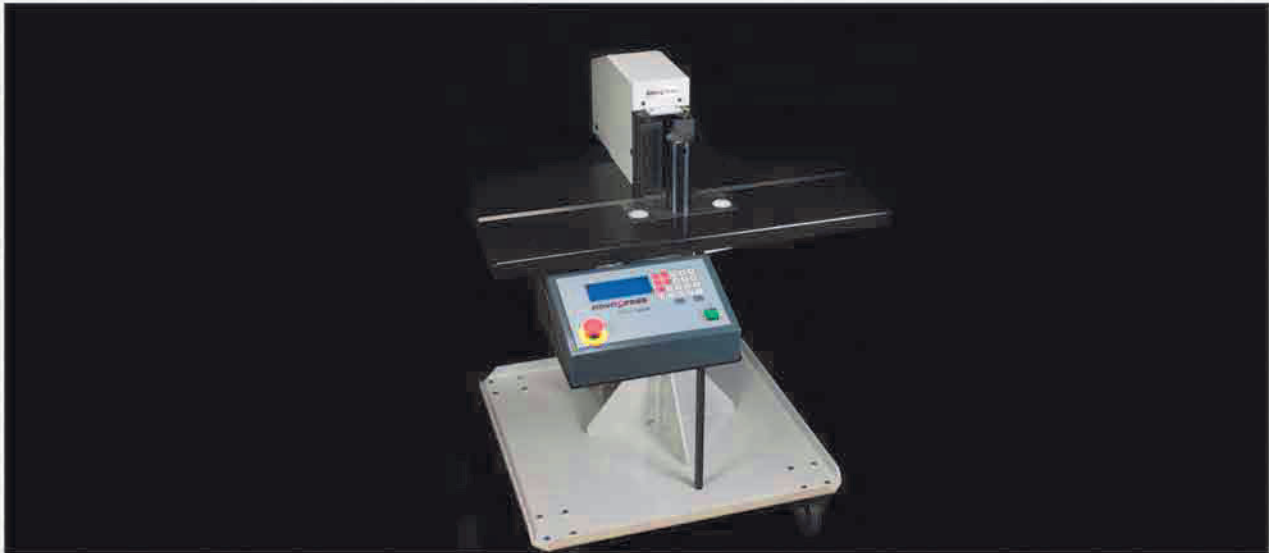

### Digital Bending Bench BGD-5eco

The BGD-5eco sets a new standard for busbar bending with outstanding precision and speed at economical prices. No other bending machine will match its range of features and performance at low entry price levels. Equipped with the essential – Digital Angle Encoder – the BGD-5eco offers unsurpassed simplicity and control with full automatic spring back compensation and bending accuracy to 0.25 degrees.

Consequently it will vanquish any need for trial bends and significantly reduce cost on faulty bend busbars. On top of this, the digital stroke encoder minimizes idle movement for the absolute shortest cycle times. Additional accessories like step or edge benders are also easy and precisely controlled by the digital stroke encoder. The new integrated hydraulic power pack takes bending speeds to new levels – 11.5 seconds – for a finished 90 degree bend including full automatic spring back compensation.



### Digital Bending Bench Advantages

- ▶ Unsurpassed bending features at economic price
- ▶ Digital Angle Encoder with precision to +/-0.25 degrees
- ▶ Full automatic spring back compensation
- ▶ No trial bends; No set up times
- ▶ Digital Stroke Encoder for minimum cycle times
- ▶ Supplied with built in high performance 3-phase power pack
- ▶ Optional step and edge bending tools for special bending applications
- ▶ Tight L-, U- and Z-bends possible
- ▶ Portable machine on wheels for ease of use

BGD-5eco  
Digital Bending Bench

**BGD-5eco**  
Technical specifications

BGD-5eco  
Accessories



### Technical specifications

Ref. No. 42380

Height	1,130 mm
Depth	950 mm
Width	830 mm
Weight	170 kg
Operating Pressure	200 bar
Force	180 KN
Bending capacity max.	160 x 13 mm (6"x1/2")
Bending radius adaptors	7.5; 10; 15 mm
Power rating	0.75 kW
Voltage	400 V 3~/50 Hz
Oil flow	3.6 l/min
Cycle time*	11.5 sec.
Cycle time** (repeat operation)	9.4 sec.
Minimum L-Bend	25 mm
Minimum U-Bend	60 mm
Minimum Z-Bend	70 mm



- \* 90° bend, 120 x 10 mm busbar size, return stroke incl. full automatic spring back compensation
- \*\* 90° bend, 120 x 10 mm busbar size repeated operation

We reserve the right to make technical modifications.

BGD-5eco  
Digital Bending Bench

BGD-5eco  
Technical specifications

BGD-5eco  
Accessories

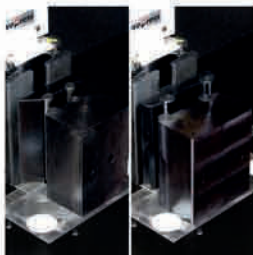
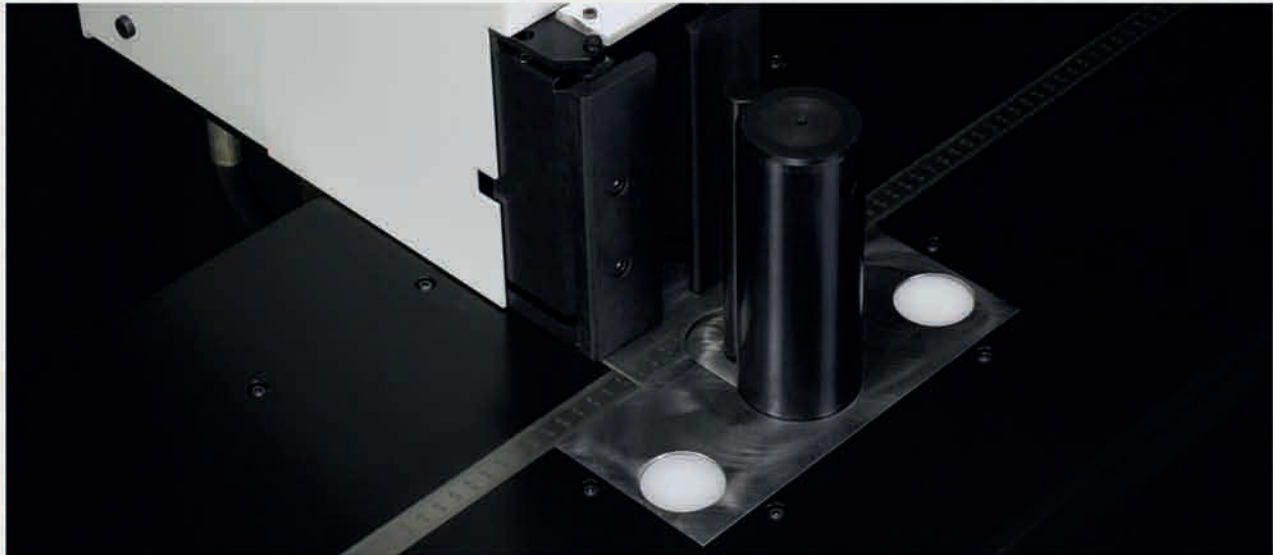

**Offset-Bending-Tools** Ref. No. 31671 (small), Ref. No. 31188 (large)

Two different Offset-Bending-Tools enable very short and 100% parallel offset bendings for your switchgear. One for copper busbar up to 80 x 8 mm (small) and the second for 120 x 10 mm busbar (large).

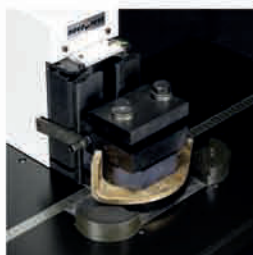

**Flat-Bending-Tool** Ref. No. 31221

With our unique Flat-Bending-Tool copper busbars up to 50 x 10 mm can be 90° flat bended. Especially on grounding busbars in the switchgear, many 90° bolt connections can be saved.

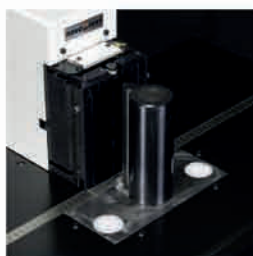

**Supplementary-Bender-BGD** Ref. No. 31850

The L-Bending-Tool allows extremely short L-bends with only 25 mm leg length. Thus, even on switchgear with very tight installation space, circuit breaker connections can be made with ease. Indispensable for modern switchgear or panel manufacturers.

We reserve the right to make technical modifications.



BGD-5eco  
Digital Bending Bench

BGD-5eco  
Technical specifications

BGD-5eco  
Accessories

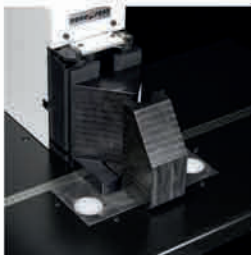
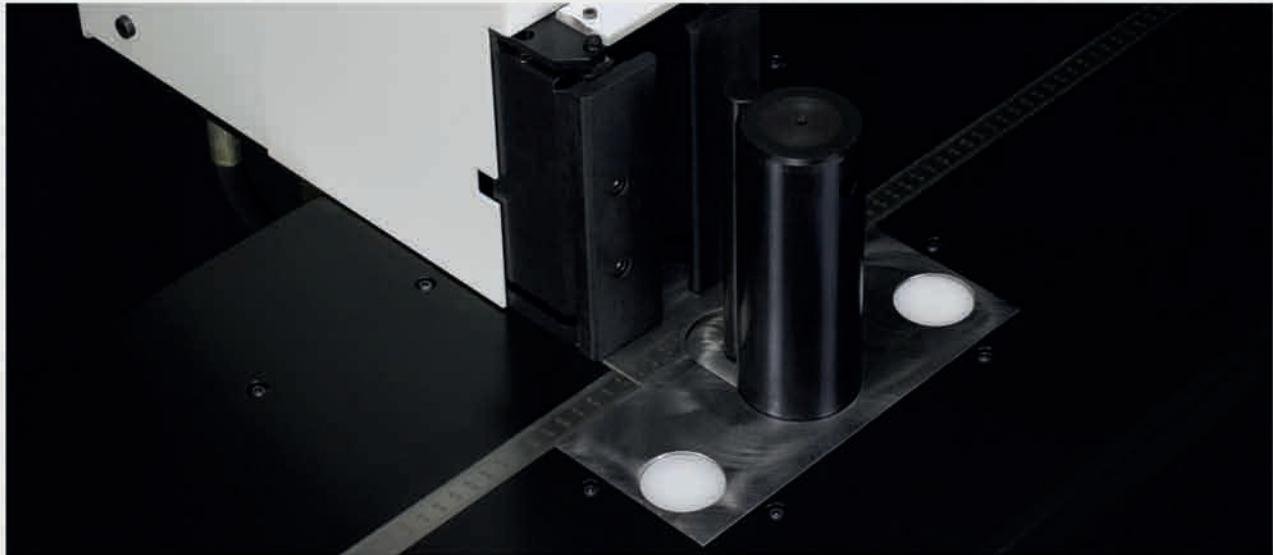

**Z-Bending-Tool** Ref. No. 45470 (small), Ref. No. 45810 (large)

By using the bending extension "Z" special step bendings can be produced. For this purpose we offer two different options. With the smaller step bending tool can be bent a 90° "Z" in copper with a maximum of 120 x 6 mm and an internal dimension (inside to inside) of 27 mm. The larger step bending tool allows bends of a 90° "Z" in copper material with a maximum of 100 x 10 mm and an internal dimension (inside to inside) of 30 mm.



**Support for BGD-5eco** Ref. No. 43255



**Software package "NovoBend"**

With our additional software package "NovoBend" bending programs can be edited on any external PC.

We reserve the right to make technical modifications.

**BGD-5.1**  
Digital Bending Bench

**BGD-5.1**  
Technical specifications

**BGD-5.1**  
Accessories



### Digital Bending Bench BGD-5.1

BGD-5.1 is the ideal bending machine for small series of busbars and individual bending work. During bending operation the digital angle measurement with full automatic spring back compensation, will ensure outstanding accuracy of  $\pm 0.25$  degrees. The automatic length stop, will travel up to 800 mm, positioning your bus bar within seconds and a precision of 0.5 mm. Last but not least, the integrated power pack takes care of convincing cycle times, at only 11.5 sec. for a full 90 degree bend including spring back compensation.

The BGD-5.1 has a USB interface to which optional a PC can be connected. There is the possibility to program serial parts either directly on the machine or from your PC. No CNC, or whatsoever programming skills are requested, but only the Novobend Software. Even complicated busbars can be created using the Software Novobend and are displayed graphically on your PC before starting the initial bending operation.



### Digital Bending Bench Advantages

- ▶ Digital angle encoder with precision to  $\pm 0.25$  degrees
- ▶ Full automatic spring back compensation
- ▶ No trial bends. No set up times
- ▶ Supplied with built in high performance 3-phase power pack
- ▶ Optional step and edge bending tools for special bending applications
- ▶ Tight L-, U- and Z-bends possible
- ▶ Programming of serial parts using the Novobend software (optional)
- ▶ USB interface for connecting a PC
- ▶ Mobile machine on wheels for ease of use

BGD-5.1  
Digital Bending Bench

BGD-5.1  
Technical specifications

BGD-5.1  
Accessories



### Technical specifications

Ref. No. 45640

Height	1,100 mm
Depth	950 mm
Width	1,630 mm
Weight	300 kg
Operating Pressure	200 bar
Force	180 KN
Bending capacity max.	160 x 13 mm (6"x1/2")
Bending radius adaptors	7.5; 10; 15 mm
Power rating	0.75 kW
Voltage	400 V 3~/50 Hz
Oil flow	3.6 l/min
Cycle time*	11.5 sec.
Cycle time** (repeat operation)	9.4 sec.
Minimum L-Bend	25 mm
Minimum U-Bend	60 mm
Minimum Z-Bend	70 mm

- \* 90° bend, 120 x 10 mm busbar size, return stroke incl. full automatic spring back compensation
- \*\* 90° bend, 120 x 10 mm busbar size repeated operation

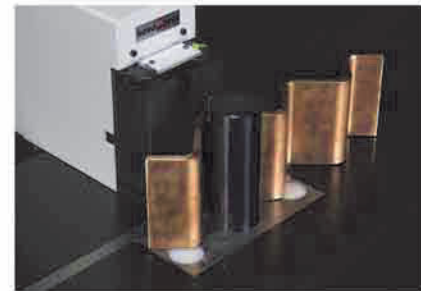

**novopress**

NovoBend 2.0



We reserve the right to make technical modifications.



BGD-5.1  
Digital Bending Bench

BGD-5.1  
Technical specifications

**BGD-5.1**  
Accessories

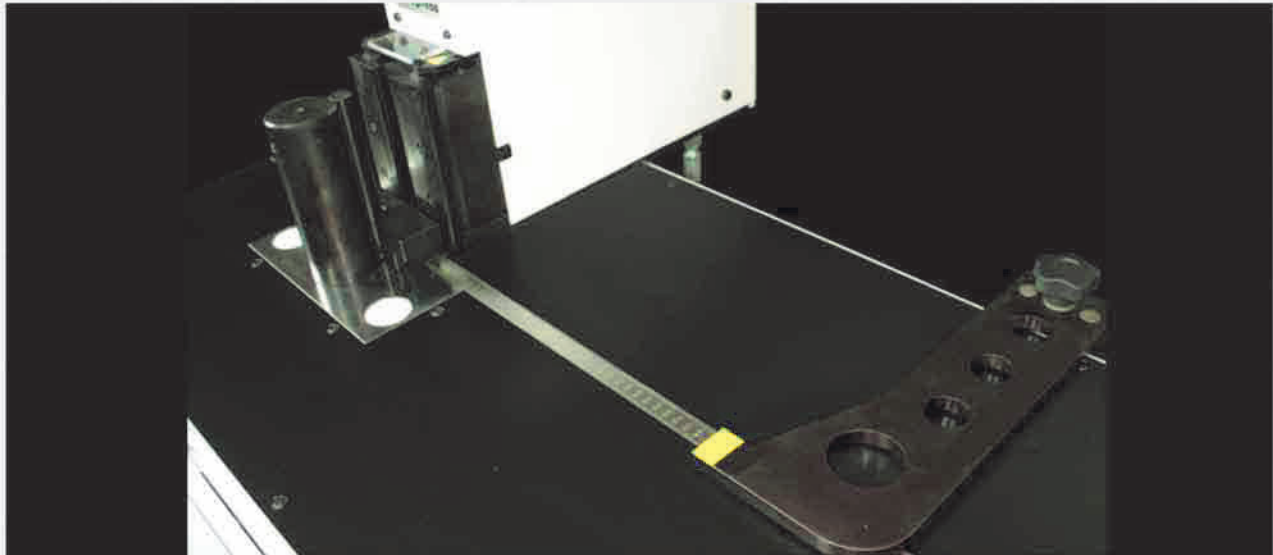

**Offset-Bending-Tools** Ref. No. 31671 (small), Ref. No. 31188 (large)

Two different Offset-Bending-Tools enable very short and 100% parallel offset bendings for your switchgear. One for copper busbar up to 80 x 8 mm (small) and the second for 120 x 10 mm busbar (large).

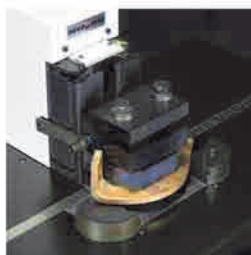

**Flat-Bending-Tool** Ref. No. 31221

With our unique Flat-Bending-Tool copper busbars up to 50 x 10 mm can be 90° flat bended. Especially on grounding busbars in the switchgear, many 90° bolt connections can be saved.

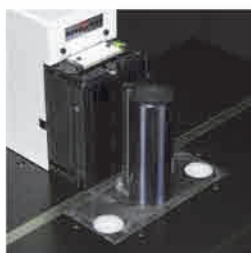

**Supplementary-Bender-BGD** Ref. No. 31850

The L-Bending-Tool allows extremely short L-bends with only 25 mm leg length. Thus, even on switchgear with very tight installation space, circuit breaker connections can be made with ease. Indispensable for modern switchgear or panel manufacturers.

We reserve the right to make technical modifications.

BGD-5.1  
Digital Bending Bench

BGD-5.1  
Technical specifications

**BGD-5.1**  
Accessories

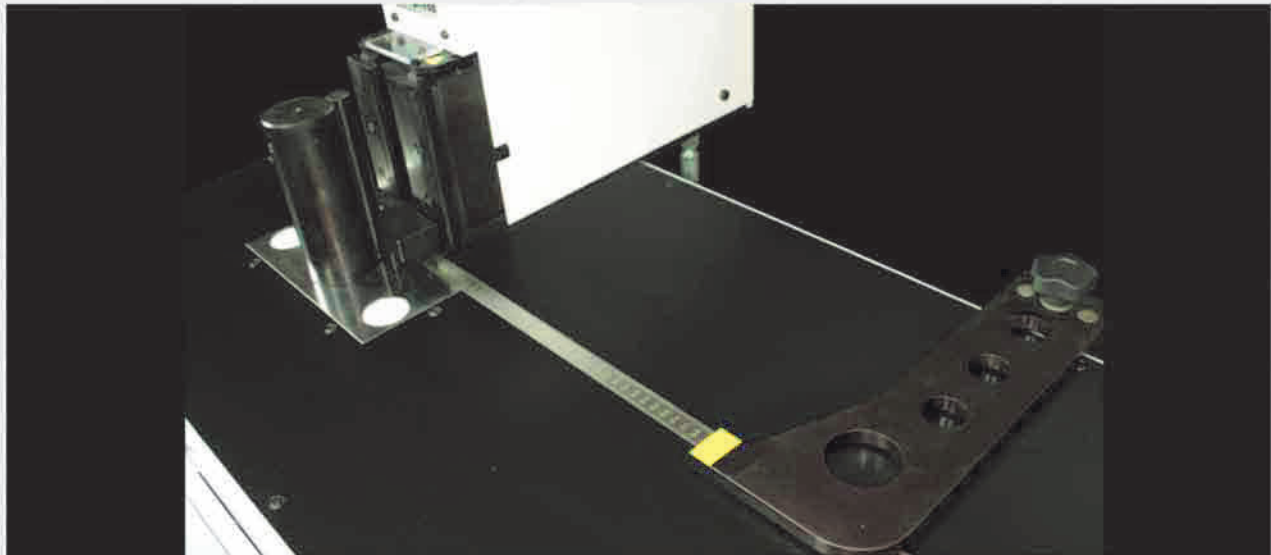

**Z-Bending-Tool** Ref. No. 45470 (small), Ref. No. 45810 (large)

By using the bending extension "Z" special step bendings can be produced. For this purpose we offer two different options. With the smaller step bending tool can be bent a 90° "Z" in copper with a maximum of 120 x 6 mm and an internal dimension (inside to inside) of 27 mm. The larger step bending tool allows bends of a 90° "Z" in copper material with a maximum of 100 x 10 mm and an internal dimension (inside to inside) of 30 mm.



**Software package "NovoBend"**

With our additional software package "NovoBend" bending programs can be edited on any external PC.

We reserve the right to make technical modifications.

**SLB 125**  
Basic unit on trolley

SLB 125  
Basic unit on trolley

SLB 125  
Complete System

SLB 125  
Accessories

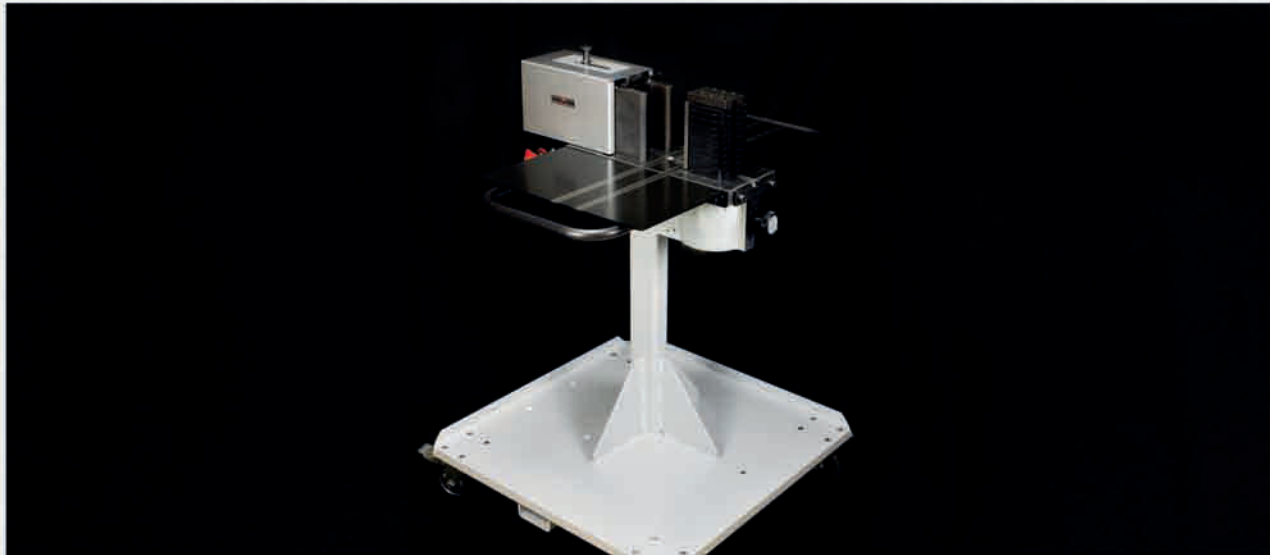

### Basic unit on trolley SLB 125

The unique SLB 125 3in1 busbar center guarantees effortless cutting, punching and bending of copper busbars up to 125 x 13 mm (4"x1/2"). Ideal for the switchgear work shop or at site the base unit transforms into a cutting, punching or bending machine within seconds.

Performance is comparable with stationary copper busbar machines, e.g. cutting of a 120 x 10 mm (4 3/4"x 3/8") copper busbar, in just 6 sec.. Punching of copper busbars is quick, effortless and without any pre-marking of the busbar. Fixed or adjustable guide plates will allow instant punching of common switchgear hole pattern. For bending of copper busbars a broad range of bending accessories will allow tight and specific bending curves as requested in modern switchgear and circuit breakers. Even processing of flexible copper busbar is possible with great safety and cutting edge quality.

Busbar fabrication from a single mould:

Precise, simple and quick.



### Basic unit on trolley Advantages

- ▶ Especially robust and stiff frame
- ▶ Lightning-swift tool changes with a minimum of manipulation
- ▶ Very high quality cutting, bending and punching
- ▶ The 150 bar low-pressure system ensures a long service life and very fast cycle times
- ▶ Busbars bent accurately up to 120° – very accurate reproducibility of the set angle
- ▶ For busbars up to 125 x 13 mm
- ▶ Accessories for flexible busbars available



SLB 125  
Basic unit on trolley

SLB 125  
Basic unit on trolley

SLB 125  
Complete System

SLB 125  
Accessories

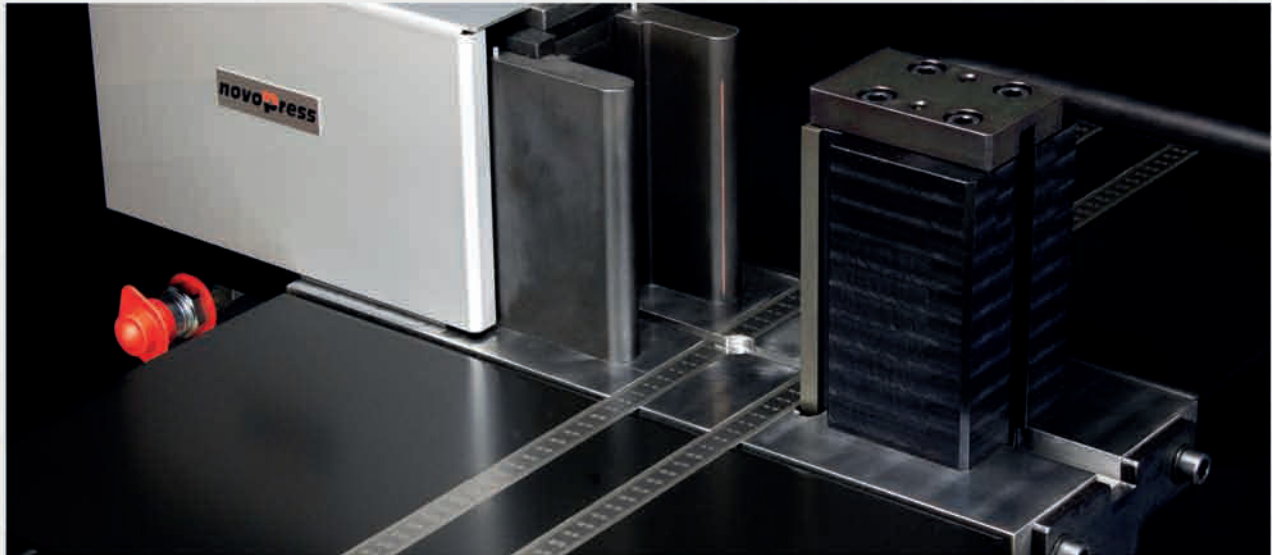

### Technical specifications

Ref.No. 40070

Height	1,145 mm
Depth	750 mm
Width	750 mm
Weight	180 kg
Operating pressure	150 bar (2.200 psi)
Force	180 KN
Power rating	0.75 kW
Voltage	230 V 1-/50 Hz
Cutting max.	125 x 13 mm 250 N/mm <sup>2</sup>
Punching max.	∅ 21 mm
Bending max.	125 x 13 mm 250 N/mm <sup>2</sup>

The unique Novopress three-in-one busbar center as a complete set - cutting, punching and bending of busbars up to 125 x 13 mm (4"x1/2") in one compact unit.

The SLB 125 Complete System comes ready to operate, including trolley, Hydraulic Power Pack HA3 and standard accessories.

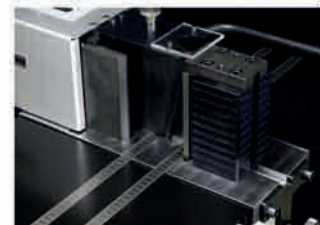

We reserve the right to make technical modifications.

SLB 125  
Basic unit on trolley

SLB 125  
Basic unit on trolley

SLB 125  
Complete System

SLB 125  
Arbeitsstrifen



**SLB 125 Kombigerät 3in1**  
**Complete System**  
Ref.No. 39659

Power Pack HA3	Ref.No. 33340
----------------	---------------

Cutting Tool	Ref.No. 31242
Bending Tool	Ref.No. 31243
Punching Tool	Ref.No. 30980
Guiding Plate	Ref.No. 31890
Tool insert 9.0 mm dia	Ref.No. 31161090
Tool insert 11.0 mm dia	Ref.No. 31161110
Tool insert 14.0 mm dia	Ref.No. 31161140

SLB 125 Basic unit on trolley	Ref.No. 40070
-------------------------------	---------------

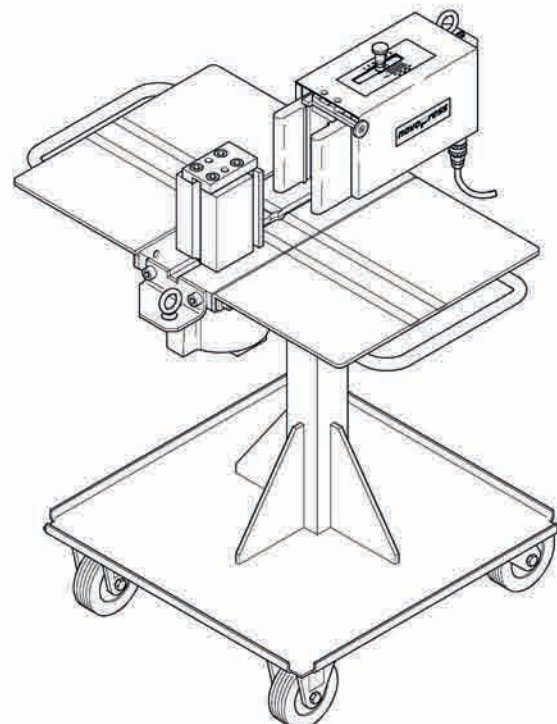
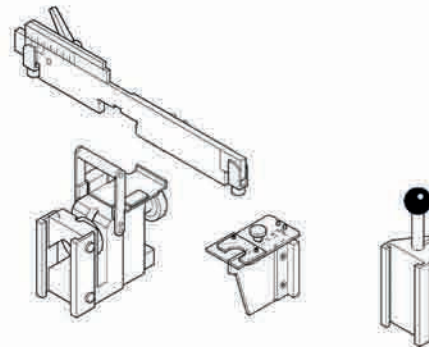
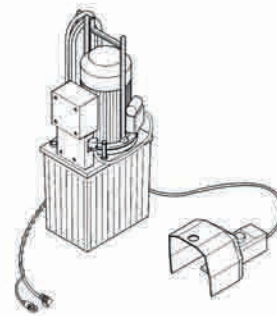

SLB 125  
Basic unit on trolley

SLB 125  
Basic unit on trolley

SLB 125  
Complete System

SLB 125  
Accessories

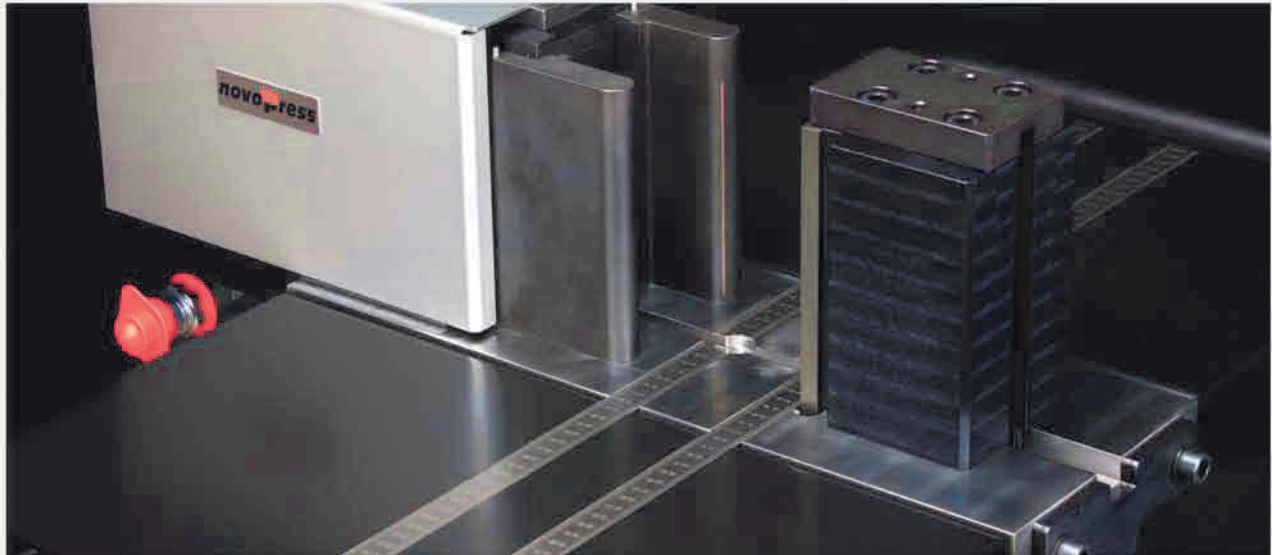

**Large-Step-Bending-Tool** Ref.No. 31646

For quick and 100 % parallel step bends on up to 120 x 10 mm busbars.  
Step = 37 mm wide and 25 mm high.



**Small-Step-Bending-Tool** Ref.No. 31425

For quick and 100 % parallel step bends on up to 80 x 8 mm busbars.  
Step = 21 mm wide and 18 mm high.



**Supplementary-Bender-SLB** Ref.No. 31636

The L-Bending-Tool will allow short "L"-bends with only 25 mm leg.  
SLB 125 standard setup will allow 45 mm as shortest leg.

We reserve the right to make technical modifications.



SLB 125  
Basic unit on trolley

SLB 125  
Basic unit on trolley

SLB 125  
Complete System

SLB 125  
Accessories

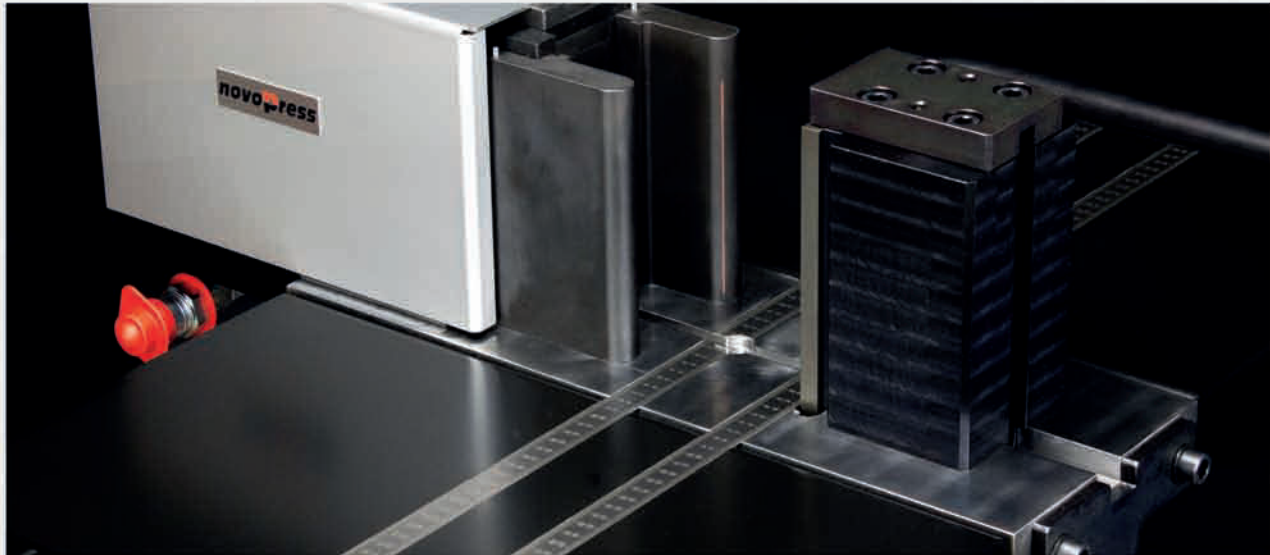

**Special-U-Bender** Ref.No. 42430

Tight U-bends are often a problem on multi-purpose copper busbar machines. With our special U-Bending-Tool you can bend your copper busbar as tight as 60 mm (2.4") inside. With this very tight copper busbar geometry your switchgear will always be "in shape".

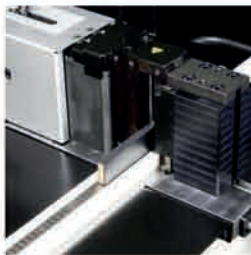

**Cutting Cartridge** Ref.No. 45445

For cutting flexible copper busbars up to 120 x 10 x 1 mm our brand new SLB 125 Cutting Cartridge is available.

With this all new cartridge cutting becomes easy, safe and of outstanding quality. The problematic copper sawing and related dust and chips are a thing of the past. Regardless of cutting insulated or stripped copper bars, subsequent processing will be trouble free. For punching flexible busbar we recommend using the special punching dies including stripper plate.

We reserve the right to make technical modifications.

HSBL-2  
Complete Systems

HSBL-2  
Starter-System

HSBL-2  
Basic-System

HSBL-2  
Standard-System



## HSBL-2 Complete Systems

In addition to individual solutions for busbar fabrication we offer complete solutions in different packages.

Starting with the "Starter-System" and the "Basic-System" up to the extensive "Standard-System" you can optimally extend your machine park for busbar fabrication.

HSBL-2  
Complete Systems

HSBL-2  
Starter-System

HSBL-2  
Basic-System

HSBL-2  
Standard-System



**HSBL-2 Starter-System**  
Ref.No. 39661-1

Power Pack HA3	Ref.No. 32530
----------------	---------------

HSBL-2 Work Cylinder	Ref.No. 2420
----------------------	--------------

**Cutting:**

Cutting Tool 160	Ref.No. 7020
------------------	--------------

**Punching:**

Punching Tool 160	Ref.No. 7050
Tool insert 9.0 mm dia	Ref.No. 200090
Tool insert 11.0 mm dia	Ref.No. 200110
Tool insert 14.0 mm dia	Ref.No. 200140

**Bending:**

Bending Tool 120	Ref.No. 1179
------------------	--------------

**Optional:**

Hydraulic Stop for 1179	Ref.No. 1627
Stop Device for 7020	Ref.No. 6990
Vice for 7020	Ref.No. 7030
Stop Device for 7050	Ref.No. 7190

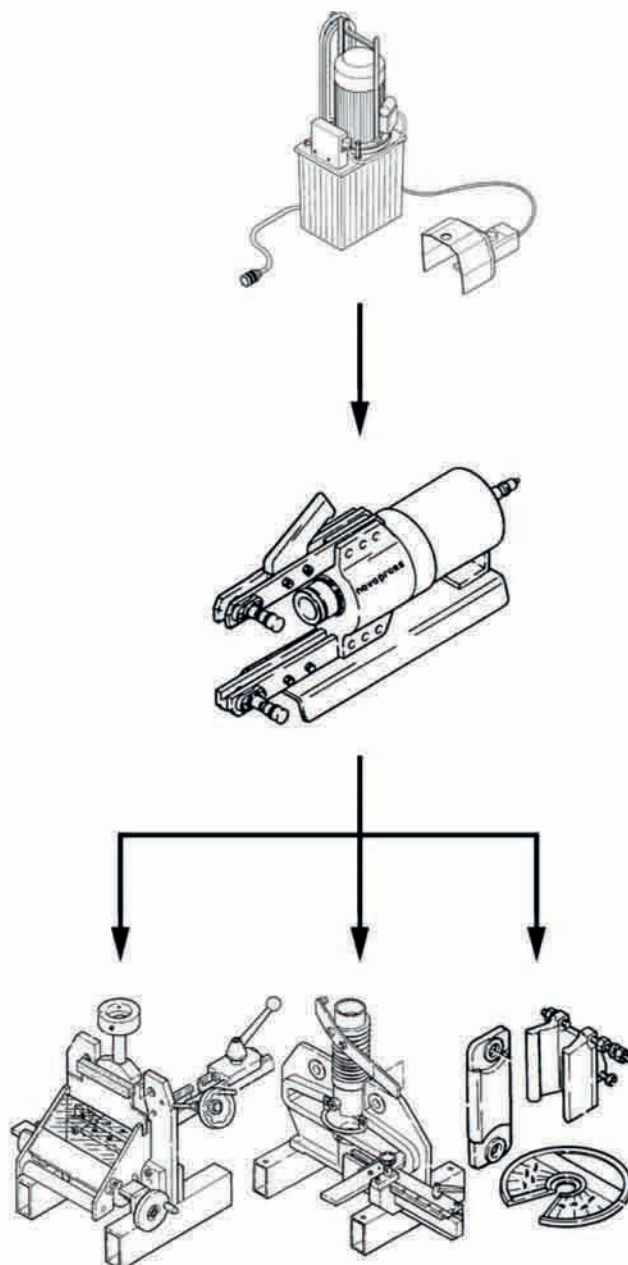



HSBL-2  
Complete Systems

HSBL-2  
Start-System

HSBL-2  
Basic-System

HSBL-2  
Standard-System



### HSBL-2 Basic-System Ref.No. 41431

Power Pack HA3	Ref.No. 32530
----------------	---------------

HSBL-2 Work Cylinder	Ref.No. 2420
----------------------	--------------

#### Cutting:

Cutting Tool 160	Ref.No. 7020
------------------	--------------

Vice for 7020	Ref.No. 7030
---------------	--------------

Stop Device for 7020	Ref.No. 6990
----------------------	--------------

#### Punching:

Punching Tool 160	Ref.No. 34243
-------------------	---------------

incl. Stop Device

Tool insert 9.0 mm dia	Ref.No. 200090
------------------------	----------------

Tool insert 11.0 mm dia	Ref.No. 200110
-------------------------	----------------

Tool insert 14.0 mm dia	Ref.No. 200140
-------------------------	----------------

#### Bending:

BGD-5eco	Ref.No. 42380
----------	---------------

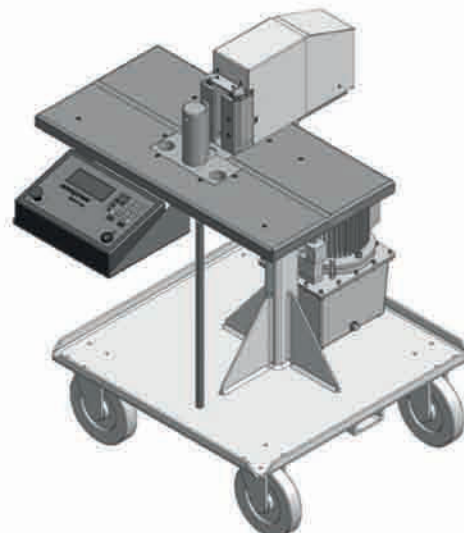
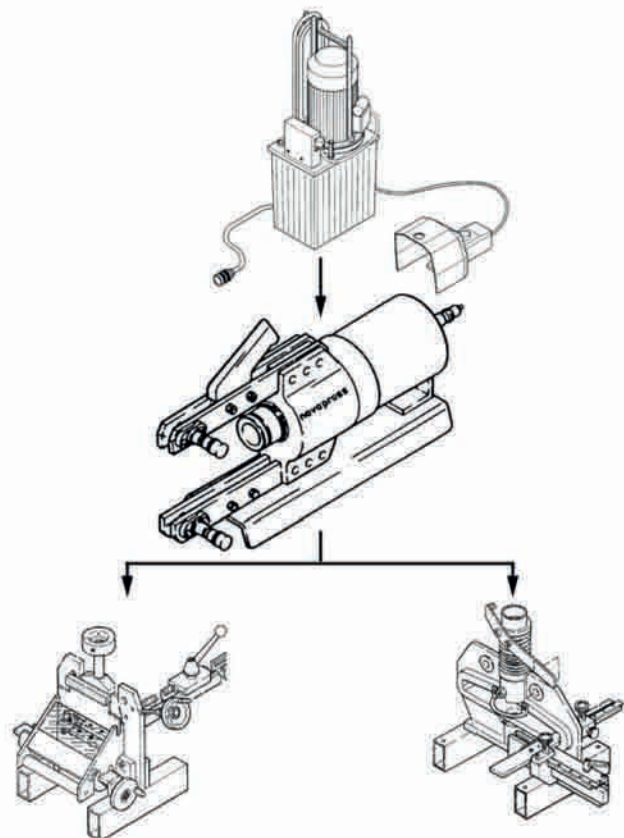

HSBL-2  
Complete Systems

HSBL-2  
Start-System

HSBL-2  
Basic-System

HSBL-2  
Standard-System



## HSBL-2 Standard-System

Ref.No. 42600

### Cutting:

Power Pack HA3	Ref.No. 32530
HSBL-2 Work Cylinder	Ref.No. 2420
Cutting Tool 160	Ref.No. 7020
Vice for 7020	Ref.No. 7030
Stop Device for 7020	Ref.No. 6990

### Punching:

Power Pack HA3	Ref.No. 32530
HSBL-2 Work Cylinder	Ref.No. 2420
Punching Tool 160	Ref.No. 34243
incl. Stop Device	
Tool insert 9.0 mm dia	Ref.No. 200090
Tool insert 11.0 mm dia	Ref.No. 200110
Tool insert 14.0 mm dia	Ref.No. 200140

### Bending:

BGD-5eco	Ref.No. 42380
----------	---------------

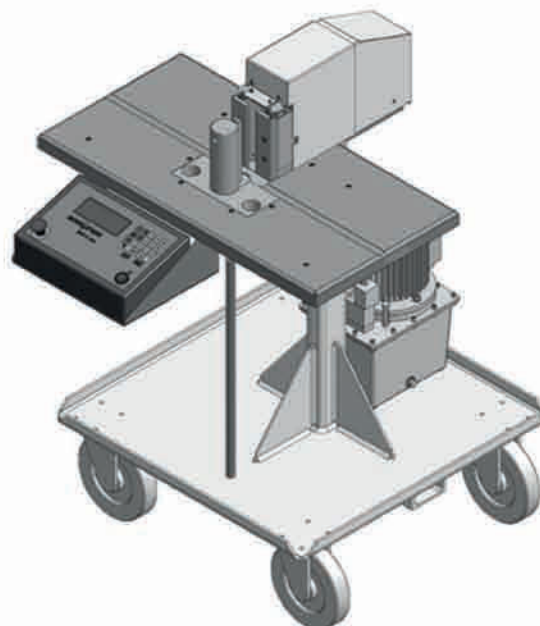
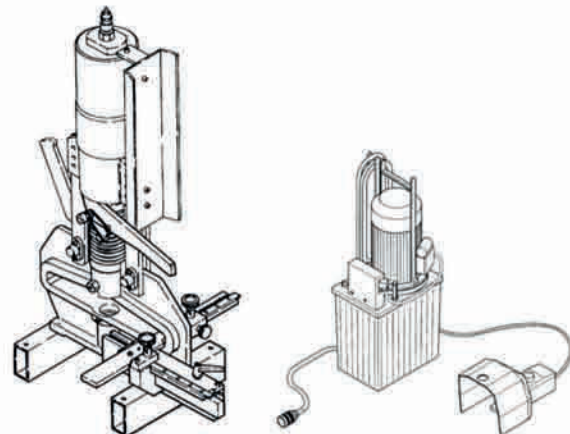
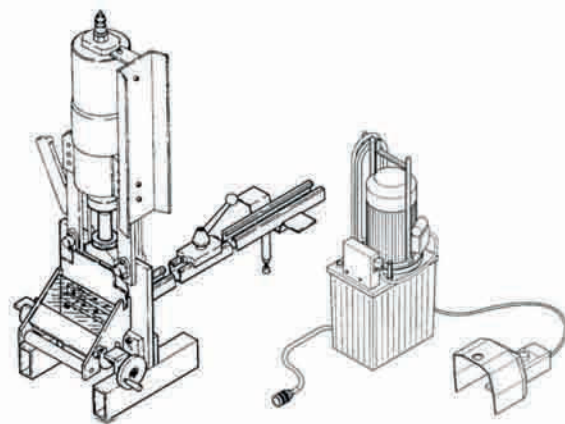

**Ref. No. 40742 HSBL-2 Profi-System 1**

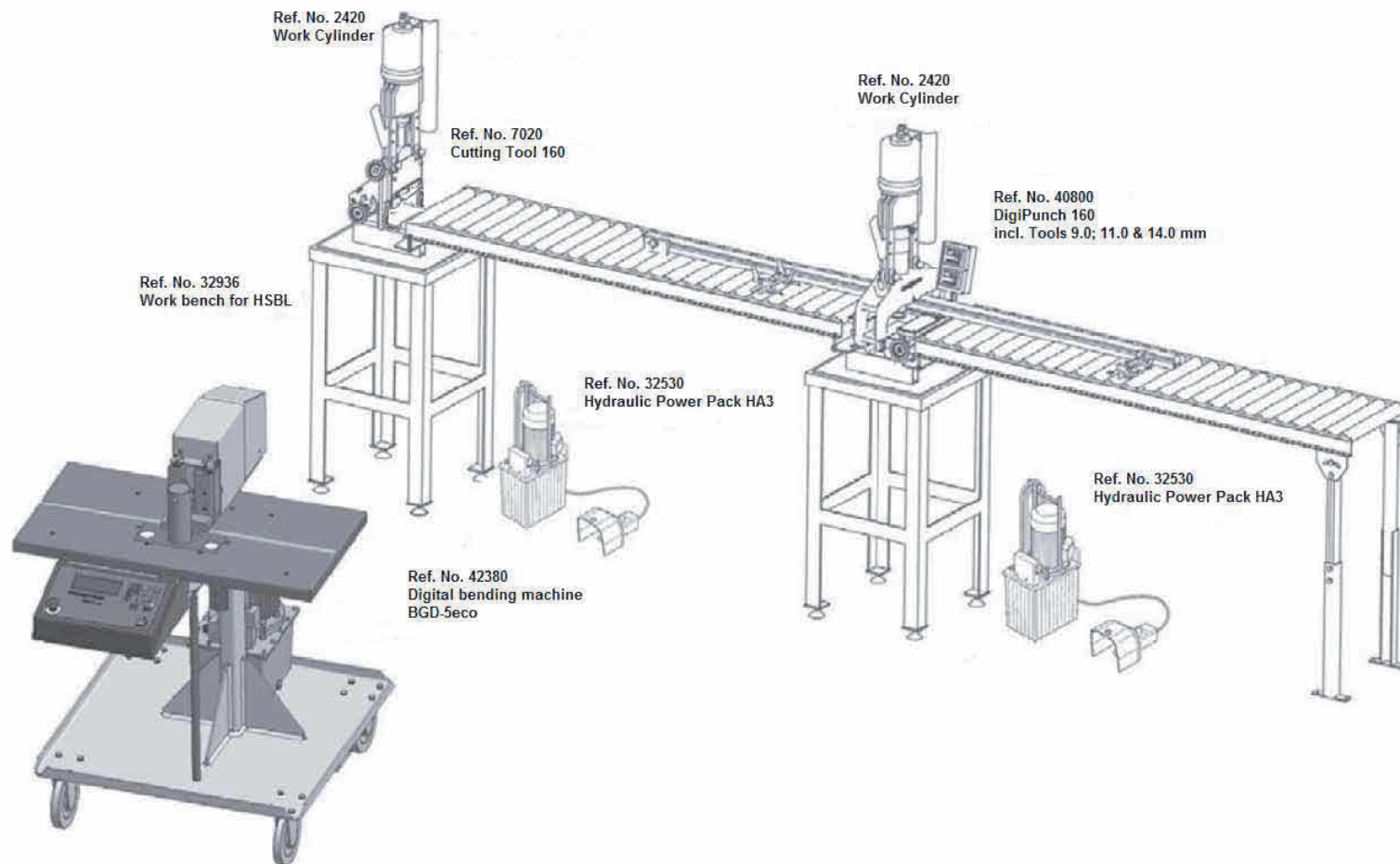



Ref. No. 40742 HSBL-2 Profi-System 1□  
Space requirements for "in-line" installation

Cutting Tool 160

DigiPunch 160

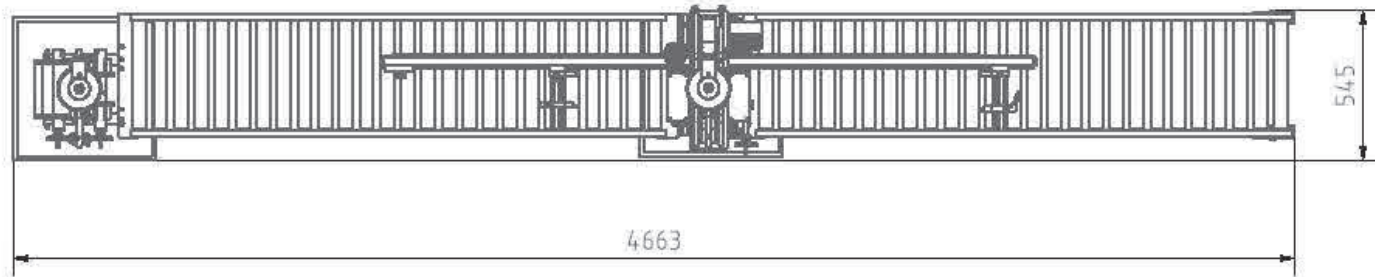

BGD-5eco

BGD-5eco Top

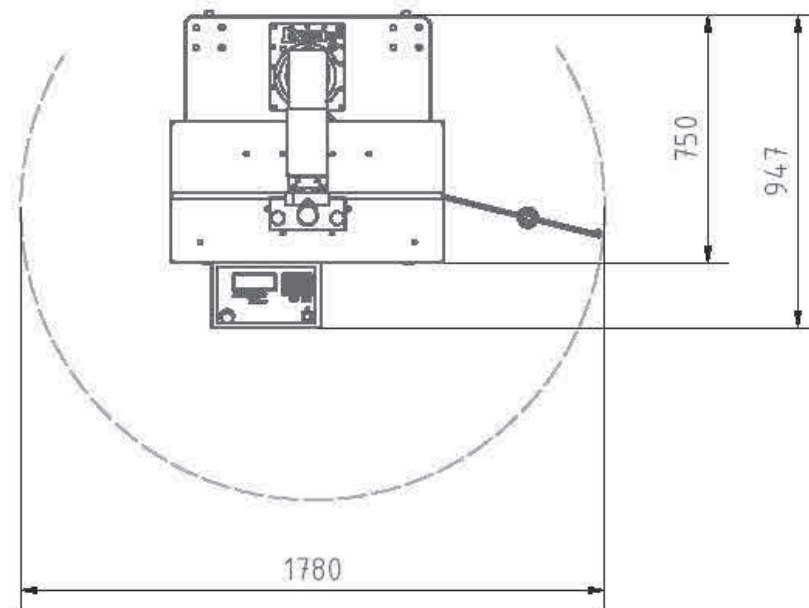
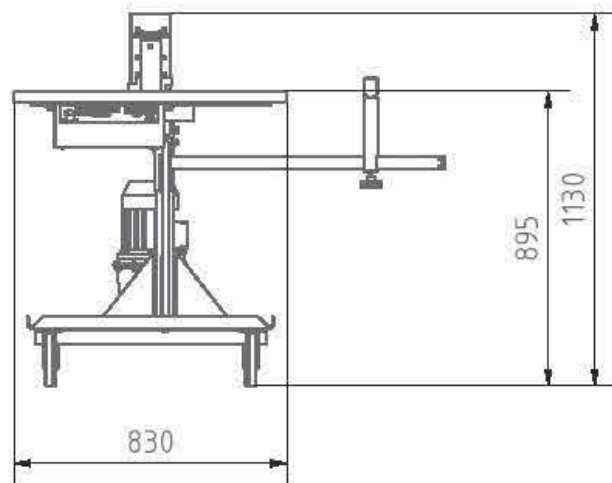

Art.-Nr. 40742 HSBL-2 Profi-System 1 □  
Space requirements for "parallel" installation

Cutting Tool 160

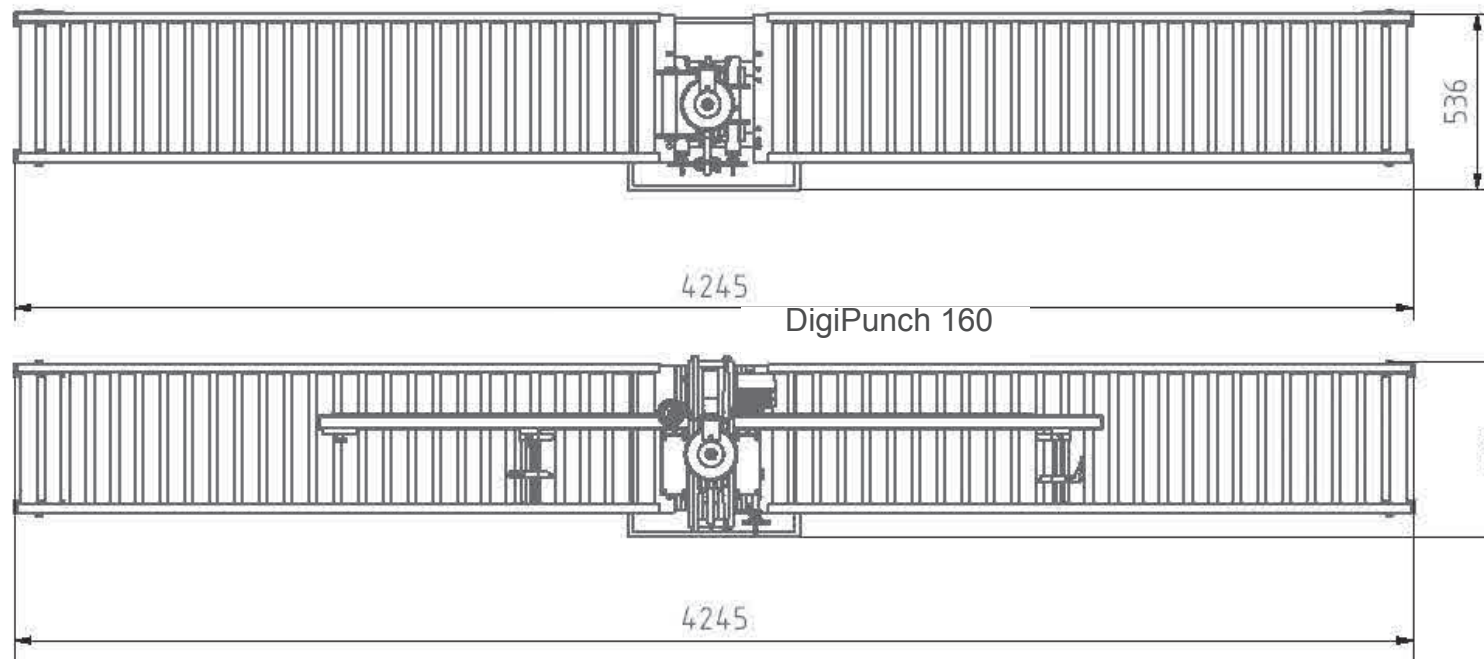

BGD-5eco

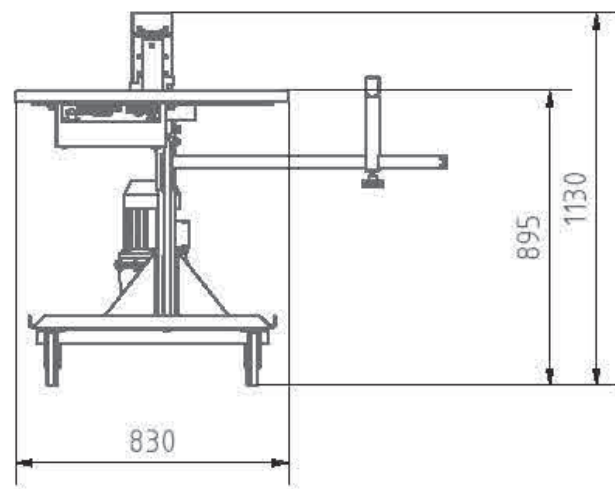

BGD-5eco Top

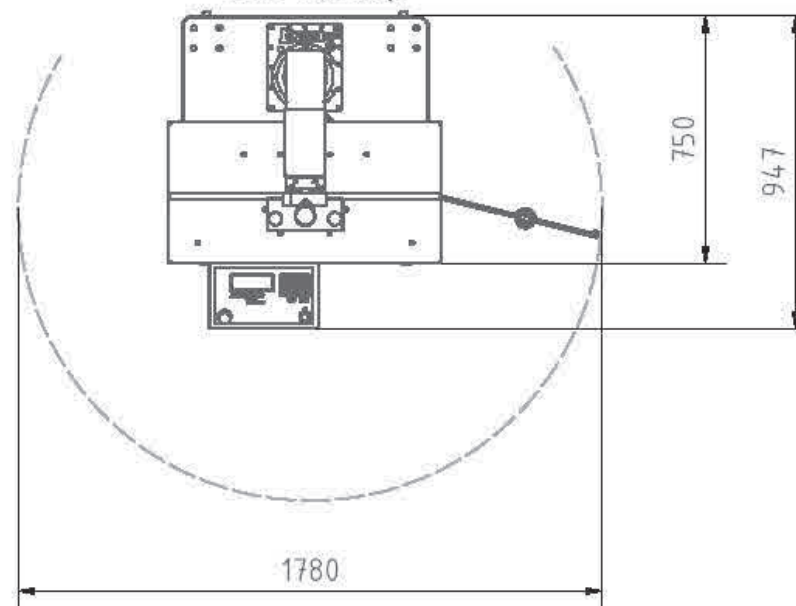

Ref. No. 41430 HSBL-2 Profi-System 2

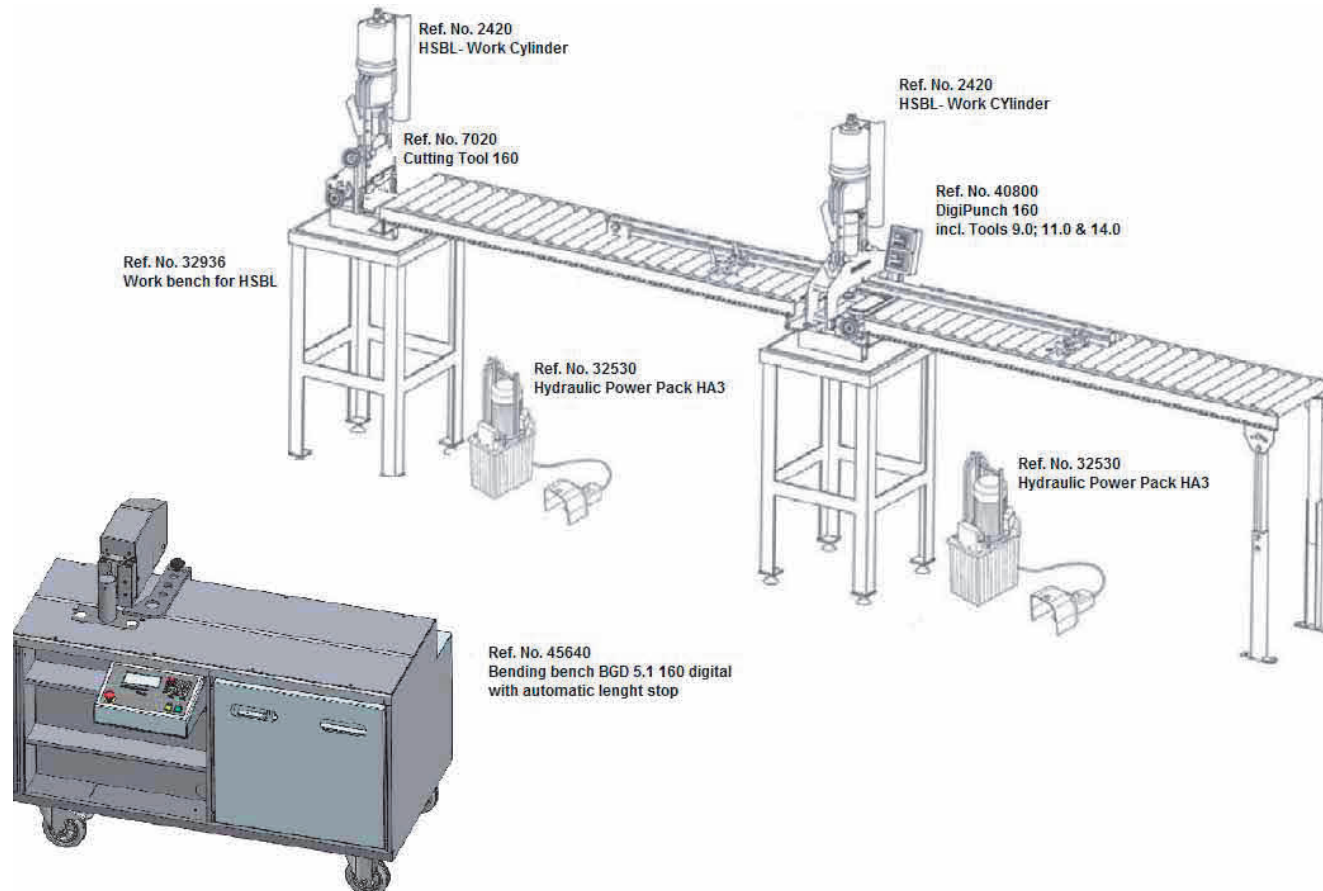



Ref. No. 41430 HSBL-2 Profi-System 2  
Space requirements for "in-line" installation

Cutting Tool 160

DigiPunch 160

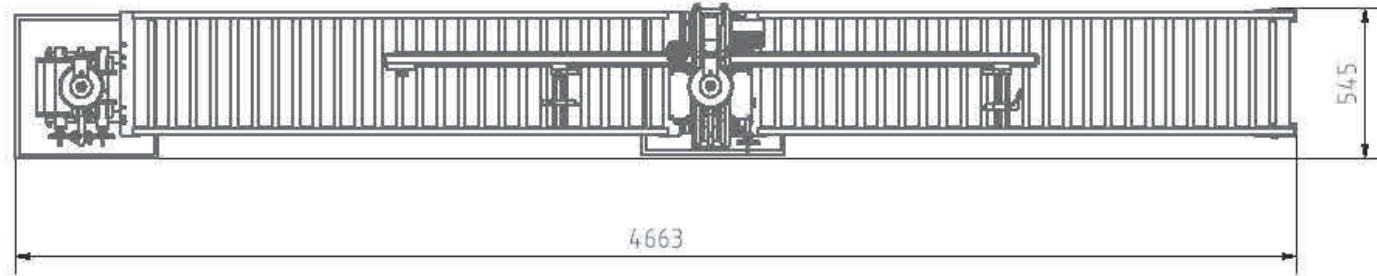

BGD 5.1

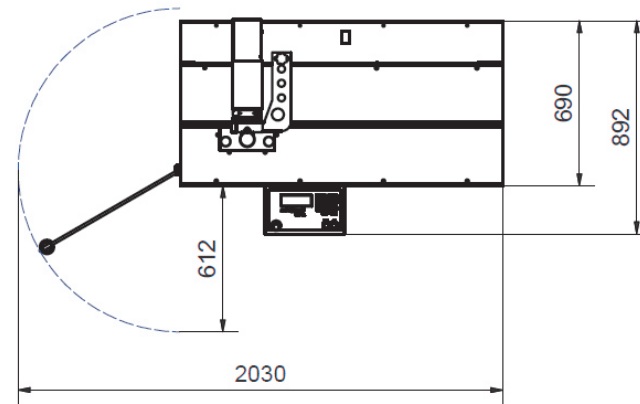
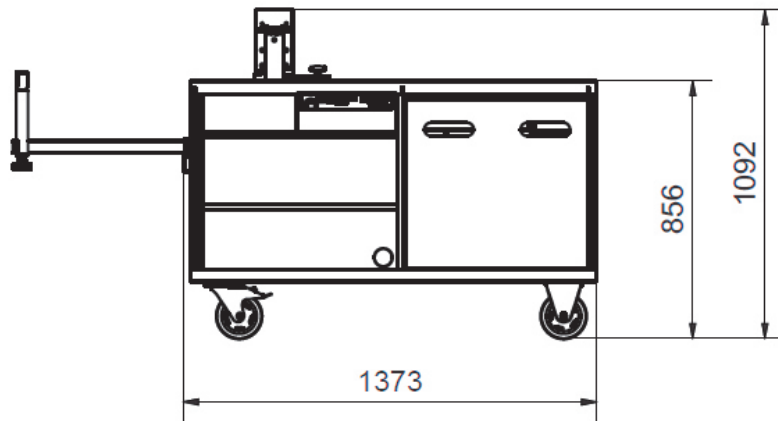

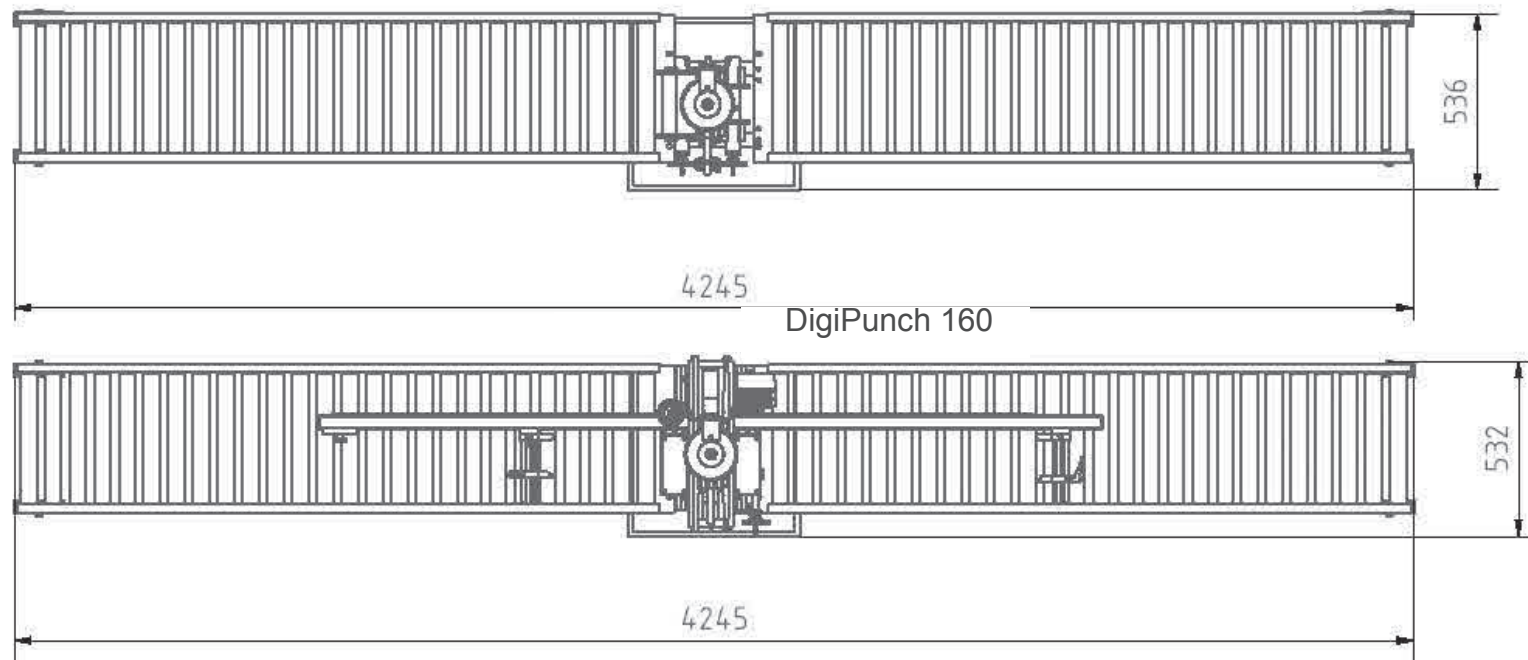

BGD 5.1

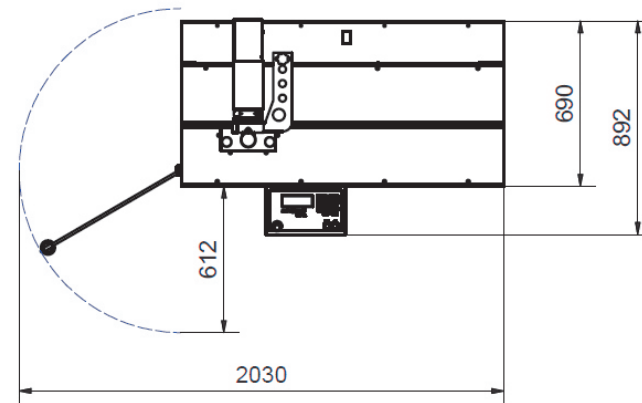
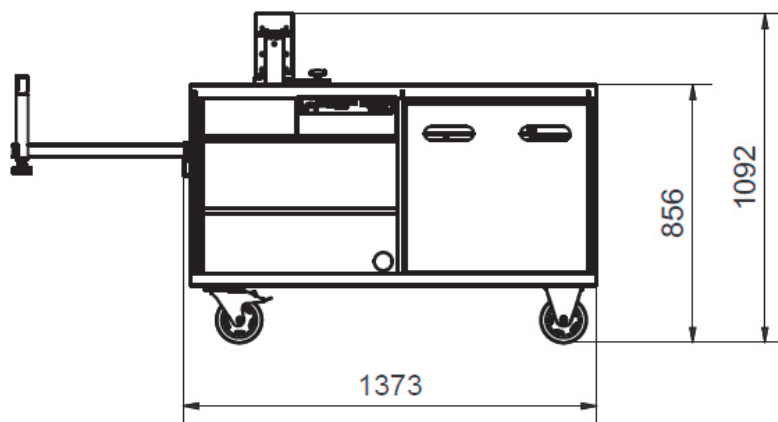

## Hydraulic Power Packs



### Hydraulic Power Packs HA1-ES and HA3

Leaders when it comes to switchgear manufacturing. Novopress hydraulic power packs are operating at a low pressure of 150 bar (2,200 psi) over a wide range of applications. This design combines the clear advantages of increased safety and long service life for the power pack and its attached devices. In addition, these hydraulic power packs area are a byword for the high quality associated with all Novopress products.



### Hydraulic Power Packs Advantages

- ▶ Durable 150 bar (2,200 psi) low pressure
- ▶ Gear pump with high flow rate
- ▶ 3-Layer safety switch
- ▶ Suitable for "S1 continuous operation" (only HA3)

	HA1-ES	HA3
Drive	E-Motor, 230 V- 800 W, 4 A	E-Motor, 230 V- 800 W, 4 A
Weight	18 kg	26 kg
Height	470 mm	550 mm
Width	280 mm	270 mm
Oil capacity	3.5 l	5.5 l
Operation	25 %, 100 s	S 1
Safety	IP 44	IP 44
Connection cable	5 m	5 m
Hydr. hose	2.5 m	2.5 m
Operating pressure	150 bar	150 bar
Flow rate	4.5 l/min	3.5 l/min

We reserve the right to make technical modifications.





IMPRINT:

Uwe Hartig Systemtechnik GmbH | CEO: Uwe Hartig  
OT Lettewitz | Wettiner Str. 24 | D- 06193 Wettin-Löbejün  
Tel. +49 3 46 03 / 2 03 68 | Fax: +49 3 46 03 / 2 10 92  
info@uwe-hartig.de | info@lettewitz.de | www.uwe-hartig.de  
USt-Id-Nr.: DE 295441589 | Amtsgericht Stendal HRB 20716

Content: Jens Schwaflo | Photos: © Andreas Richter  
All contents, texts, pictures and graphics are copyrighted  
protected. You may not without prior written consent of  
Company "Uwe Hartig Systemtechnik GmbH" in whole or  
in part, copied, modified, reproduced or published.